

02

+MOAM

+MOAM PLUS

+SPRING GARDEN

+PAMO

SISTEMI MOTORIZZATI
MOTORIZED SYSTEM







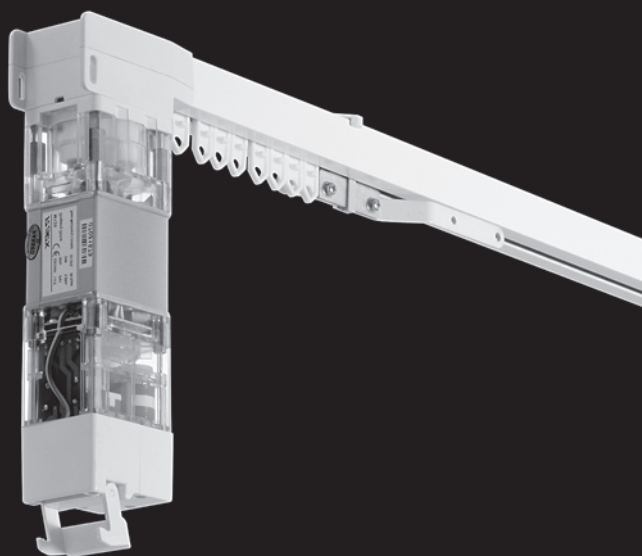







SCALA 1:2

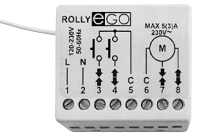

	+CODICE CODE	+DESCRIZIONE DESCRIPTION	+IMBALLO PACKING
	MA 001.005	Binario per sistema motorizzato, bianco, m. 7 White rail for american motorized system, m. 7	m/m 35
	AS 100.005	Scivolo con rullino stampato Glider with moulded runner	pz/pc 1000
	AS 100.001	Scivolo con rullino tornito Glider with lathed runner	pz/pc 1000
	AS 652.005	Scivolo per canale largo Glider for large channel	pz/pc 1000
	CA 100.005	Cinta di trasmissione dentata Toothed transmission belt	m/m 100
	CA 115.005	Carrello lama ferro Master carrier	pz/pc 20
	CA 115.005/F	Carrello lama ferro frizionato Clutch master carrier	pz/pc 20

	+CODICE CODE	+DESCRIZIONE DESCRIPTION	+IMBALLO PACKING
	CB 100.005	Cavo Cable	m/m 20
	FA 100.005	Fermo con occhiolo End stop with eyelet	pz/pc 100
	GA 001.005	Giunzione per binario Rail junction	pz/pc 10
	IT 100.005	Connettore Power socket	pz/pc 20
	MA 045.005	Motore principale 45 W Main motor 45 W	pz/pc 10
	MA 145.005	Motore secondario 45 W Secondary motor 45 W	pz/pc 10
	MA 100.005	Testata guida Motor unit	pz/pc 10
	MA 101.005	Testata rinvio Idler unit	pz/pc 10
	MR 100.005	Modulo radio 1 motore Radio module for 1 motor	pz/pc 10
	PA 100.005	Supporto a chiavetta Key	pz/pc 100

	+CODICE CODE	+DESCRIZIONE DESCRIPTION	+IMBALLO PACKING
	PT 001.005	Pulsantiera radio 1 canale 1 Channel radio panel control	pz/pc 1
	PT 002.005	Pulsantiera radio 2 canali 2 Channel radio panel control	pz/pc 1
	PT 015.005	Pulsantiera radio 15 canali 15 Channels radio panel control	pz/pc 1
	TC 001.005	Trasmittitore 1 canale 1 Channel transmitter	pz/pc 1
	TC 003.005	Trasmittitore 3 canali 3 Channels transmitter	pz/pc 1
	TC 024.005	Trasmittitore 24 canali 24 Channels transmitter	pz/pc 1



Galtex Lines srl

via Liguria 20 - 60030 Monsano An Italy - tel +39 0731 60151 - fax +39 0731 619811 - info@carmeli.it - www.carmeli.it