

02

+MOAM

+MOAM PLUS

+SPRING GARDEN

+PAMO

SISTEMI MOTORIZZATI
MOTORIZED SYSTEM





SCALA 1:2



+CODICE
 CODE

+DESCRIZIONE
 DESCRIPTION

+IMBALLO
 PACKING



MA 001.005

Binario per sistema motorizzato, bianco, m. 7
 White rail for american motorized system, m. 7

m/m 35



AS 200.005

Scivolo
 Glider

pz/pc 100



CA 100.005

Cinta di trasmissione dentata
 Toothed transmission belt

m/m 100



CA 115.005

Carrello lama ferro
 Master carrier

pz/pc 100



CA 115.005/F

Carrello lama ferro frizionato
 Clutch master carrier

pz/pc 100



CB 100.005

Cavo
 Cable







m/m 20



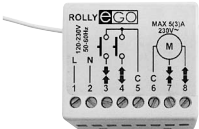

FA 100.005

Fermo con occhio
 End stop with eyelet

pz/pc 100

	+CODICE CODE	+DESCRIZIONE DESCRIPTION	+IMBALLO PACKING
	GA 001.005	Giunzione per binario Rail junction	pz/pc 10
	IT 100.005	Connettore Power socket	pz/pc 20
	MA 045.005	Motore principale 45 W Main motor 45 W	pz/pc 10
	MA 145.005	Motore secondario 45 W Secondary motor 45 W	pz/pc 10
	MA 100.005	Testata guida Motor unit	pz/pc 10
	MA 101.005	Testata rinvio Idler unit	pz/pc 10
	MR 100.005	Modulo radio 1 motore Radio module for 1 motor	pz/pc 10
	PA 100.005	Supporto a chiavetta Key	pz/pc 100
	PT 001.005	Pulsantiera radio 1 canale 1 Channel radio panel control	pz/pc 1
	PT 015.005	Pulsantiera radio 15 canali 15 Channels radio panel control	pz/pc 1

	+CODICE CODE	+DESCRIZIONE DESCRIPTION	+IMBALLO PACKING
	SP 100.005	Tubo radiale Ø mm. 14 Pole Ø mm. 14	m/m 30
	TC 001.005	Trasmittitore 1 canale 1 Channel transmitter	pz/pc 1
	TC 003.005	Trasmittitore 3 canali 3 Channels transmitter	pz/pc 1
	TC 024.005	Trasmittitore 24 canali 24 Channels transmitter	pz/pc 1



+PORTATA
RANGE

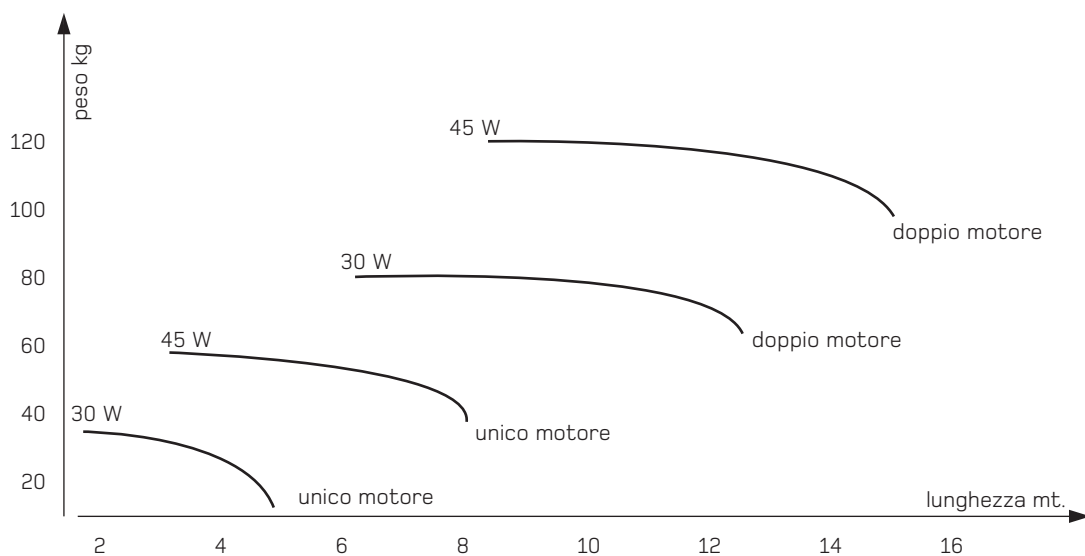

+CAPACITÀ DI CARICO
LOAD CAPACITY

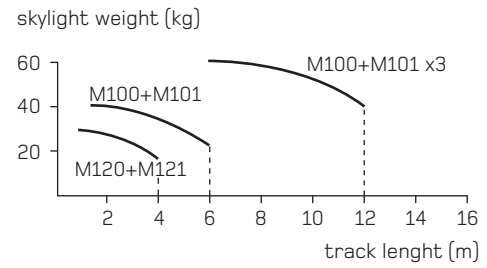
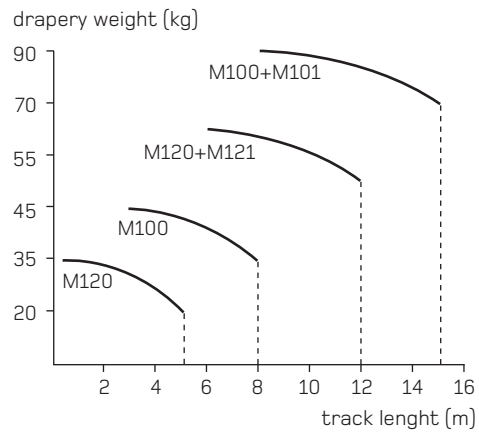

+METODO DI CONNESSIONE
CONNECTION METHOD

Single motor system

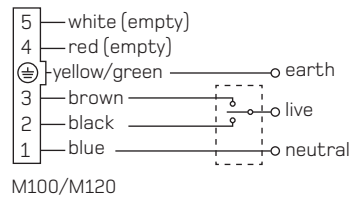

Tandem motors system

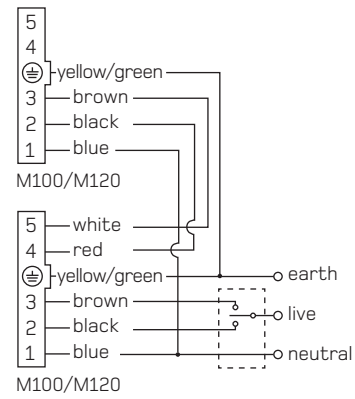

+SCHEMA DI COLLEGAMENTO
CONNECTION SCHEME

MR 100.005

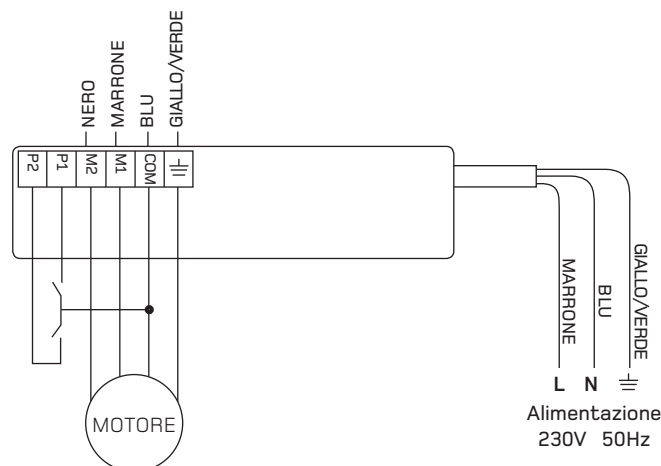



Galtex Lines srl

via Liguria 20 - 60030 Monsano An Italy - tel +39 0731 60151 - fax +39 0731 619811 - info@carmeli.it - www.carmeli.it